

Renewable Energy Lab Equipment

YPCTK-100 / YSEGT-1000 / YWEGT-1000 (B) / YWEGT-1000 (H) / YSEGT-2000

User can learn the knowledge of principles and development system about Solar Power and Wind Power. Control Practice is possible by separately deviding each Module units. Whole system is configured to control in real - time. This is the training system which helps to breed up the human resources for the Renewable Energy Industry.



YWEGT-1000 (H)



YSEGT-2000



YWEGT-1000 (B)



YSEGT-1000



YPCTK-100

Power Conversion Training Kit

Model: YPCTK-100



YPCTK - 100 Features

1. The power conversion module is designed as an experiment and practice system for electronics and is suitable for students beginning with DC-DC Converter.
2. Circuit operation can be understood through manufacturing practice for each module.
3. It is possible to conduct experiment and practice to check change in output voltage of BUCK BOOST and CUK Modules by adjusting PWM Gen output DUTY cycle.
4. The textbook is edited and provided in the order of theory, manufacturing practice and report.



YPCTK-100 Functions

1. Education and training system for power conversion
2. Education and training for manufacturing 5 modules
3. STEP_UP DC-DC Converter manufacturing
4. STEP_DOWN DC-DC converter manufacturing
5. BUCK BOOST DC-DC Converter manufacturing
6. CUK DC-DC Converter manufacturing

Contents of YPCTK - 100 Textbook

1. Principle of SMPS(Switching Mode Power Supply)
2. PWM Generator Operation and practice
3. Non - isolated Converter, Boost(Step_up) operation and practice
4. Non - isolated Converter : Buck(Step_down) operation and practice
5. Non - isolated Converter : Buck - Boost (Step_up/down) operation and practice
6. Non - isolated Converter : CUK(Step_up/down) operation and practice

YPCTK - 100 Specification

Part	Specification
Module	Specification
PWM Generator	25KHz 5V output Duty Ratio 2~45% ADJ SIZE : 150 X 85(mm) Input : DC12V
Boost(Step_up)	Output : DC 12~36V ADJ SIZE : 150 X 85(mm) Input : DC12V
Boost(Step_down)	Output : DC 0~12V ADJ SIZE : 150 X 85(mm) Input : DC12V
BUCK BOOST (Step up/down)	Output : DC 0~36V ADJ SIZE : 185 X 155(mm) Input : DC12V
CUK (Step up/down)	Output : DC 0~40V ADJ SIZE : 185 X 155(mm)
Cable	SMA CABLE 75MM

YPCTK - 100 Components

Part	Spec	Qty
Training Module	PWM Generator	Module 1
	Boost(Step_up)	1
	Boost(Step_down)	1
	BUCK BOOST(Step up/down)	1
	CUK (Step up/down)	1
SMA CABLE	EA	1
Textbook	Volume	1

Solar Energy Generation Trainer

Model: YSEGT-1000



[Patent Applied No. 10 - 2010 - 0134493]

Y SEGT - 1000 Features

1. Helps users understand solar energy generating system by combining light source, charging controllers, converter, inverter, etc as a module.
2. Provides customized power generation system designing practices for manufacturing commercial products or practical training.
3. Every module is controlled through computer and has test pins for users to measure characteristics of each circuit.
4. Every module can be powered by battery during practices.
5. Power efficiency of each module is displayed on GUI in real time.
6. Incident angle of light source can be changed.
7. Each chapter of text book has objective of practice, theories, practices and report.

Y SEGT - 1000 Functions

1. Understanding structure and concept of solar energy generation system
2. Understanding & designing energy conversion process
3. Understanding structure and principles of various inverters and converters
4. Users can analyze difference in energy generating efficiency according to incidence angle of light.
5. Supports capacity expansion practice through serial/parallel connection of solar cells.
6. Supports tracking system control practices using microprocessor.
7. Beep sounds when connecting module to other module with opposite polarity.

Y SEGT - 1000 Training contents

- Chapter 1 Overview and composition of solar energy generation
 - Chapter 2 Types and characteristics of solar cell
 - Chapter 3 I-V characteristics of solar cell
 - Chapter 4 Serial/parallel connection characteristics of solar cell
 - Chapter 5 Understanding PWM control circuit
 - Chapter 6 PWM power control by using microcontroller
 - Chapter 7 Practices about applications of PWM power control
 - Chapter 8 Overview of converter
 - Chapter 9 Designing StepUp converter
 - Chapter 10 Designing StepDown converter
 - Chapter 11 Overview and types of inverter
 - Chapter 12 Designing insulation inverter
 - Chapter 13 Designing not insulation inverter
 - Chapter 14 Overview of charging/discharging system
 - Chapter 15 PC monitoring practice by using GUI /
- Appendix DATA SHEET(LM2576, LM2577, TL494)

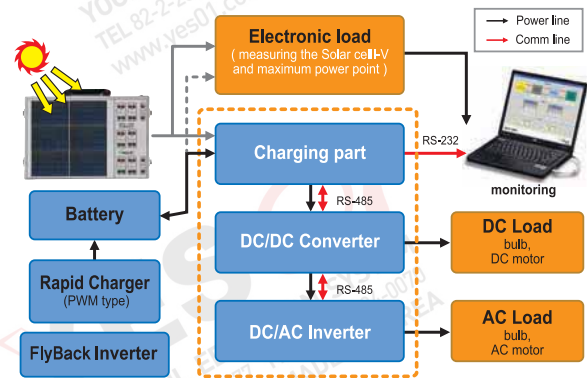

System Block Diagram

Y SEGT - 1000 Specifications

Div	Spec
Solar cell	6V 2.5W(6EA) , tracking system (option)
Light source	500W Halogen lamp
Battery	12V 12Ah Non-leakage and sealed Battery
Charge Controller	DC6 - 40V ==> DC12V Charge(Step Up, Step Down method) Applied protection circuitry for Overcharge, Over-discharge
Rapid Charger	AC220V DC 15V 2A (PWM method)
DC/DC Converter	DC12V DC230V (PWM method)
DC/AC Inverter	DC230V AC220V (PWM method)
FlyBack Inverter	DC12V AC220V(PWM method)
AC Load	Incandescent lamp, Fluorescent lamp, AC motor
DC Load	LED, DC motor

Y SEGT - 1000 Components

Div	quantity
Sollar set	1set
Module set(8 Classes)	1set
RS - 485 Cable	4EA
USB Cable	1EA
Banana cable	1set
12V BATTERY	2EA
Text book	1EA
Firmware CD	1EA

Solar Energy Generation Trainer

Model: YSEGT-2000



Y SEGT - 2000 Features

1. Helps users understand solar energy generating system by combining light source, charging controllers, converter, inverter, etc as a module.
2. Provides customized power generation system designing practices for manufacturing commercial products or practical training.
3. Every module is controlled through computer and has test pins for users to measure characteristics of each circuit.
4. Every module can be powered by battery during practices.
5. Power efficiency of each module is displayed on GUI in real time.
6. Incident angle of light source can be changed.
7. Each chapter of text book has objective of practice, theories, practices and report.

Y SEGT - 2000 Training contents

- Chapter 1 Overview and composition of solar energy generation
 - Chapter 2 Types and characteristics of solar cell
 - Chapter 3 I - V characteristics of solar cell
 - Chapter 4 Serial/parreral connection characteristics of solar cell
 - Chapter 5 Understanding PWM control circuit
 - Chapter 6 PWM power control by using microcontroller
 - Chapter 7 Practices about applications of PWM power control
 - Chapter 8 Overview of converter
 - Chapter 9 Designing StepUp converter
 - Chapter 10 Designing StepDown converter
 - Chapter 11 Overview and types of inverter
 - Chapter 12 Designing insulation inverter
 - Chapter 13 Designing not insulation inverter
 - Chapter 14 Overview of charging/discharging system
 - Chapter 15 PC monitoring practice by using GUI /
- Appendix DATA SHEET(LM2576, LM2577, TL494)

Y SEGT - 2000 Functions

1. Understanding structure and concept of solar energy generation system
2. Understanding&designing energy conversion process
3. Understanding structure and principles of various inverters and converters
4. Users can analyze difference in energy generating efficiency according to incidence angle of light.
5. Supports capacity expansion practice through serial/parallel connection of solar cells.
6. Supports tracking system control practices using microprocessor.
7. Beep sounds when connecting module to other module with opposite polarity.

Y SEGT - 2000 Specifications

Div	Spec
Solar cell	18V 10W(2EA) , tracking system
Light source	500W Halogen lamp
Battery	12V 12Ah Non -leakage and sealed Battery
Charge Controller	DC6 - 40V ==> DC12V Charge(Step Up, Step Down method) Applied protection circuitry for Overcharge, Over - discharge
Rapid Charger	AC220V DC 15V 2A (PWM method)
DC/DC Converter	DC12V DC230V (PWM method)
DC/AC Inverter	DC230V AC220V (PWM method)
FlyBack Inverter	DC12V AC220V(PWM method)
AC Load	Incandescent lamp, Fluorescent lamp, AC motor
DC Load	LED, DC motor

Y SEGT - 2000 Components

Div	quantity
Main Body	1SET
RS - 485 Cable	4EA
USB Cable	1EA
Banana cable	1set
Text book	1EA
Firmware CD	1EA
Tracking system	1EA

Wind Energy Generation Training System

Model: YWEGT-1000 Blade Type



YWEGT-1000 (Blade Type) features

1. Designed to allow indoor experiments for the principle of wind power generation
2. The system is composed of blower, blade, load module, wind speed meter, DC/AC inverter, battery and quick charger
3. For the purpose of safety, load and inverter modules are contained in a steel enclosure
4. Blade support frame is provided to endure the wind pressure when wind is applied to the blade by the blower.
5. Real-time wind speed measurement using a wind speed meter.
6. The load module is equipped with an LCD for real-time checking of blade RPM.
7. The DC/AC inverter module is equipped with an LCD to check voltage and current.
8. Each chapter of the training textbook is composed of theory, practice and report.
9. Manufacturing practice for power conversion and measurement of circuit characteristics

YWEGT-1000 (Blade Type) functions

1. Measuring energy vs. number of blades
2. Measuring energy vs. blade angle
3. Measuring energy vs. the speed of blower
4. Measuring blade RPM vs. load
5. Manufacturing power conversion circuit.

YWEGT-1000 (Blade Type) Part Specification

Part	Specification
Blower	Rated voltage 220V
	Power consumption: 1060W
	Diameter: 0.5m
Blade	Voltage regulator: Single phase 220V
	Rotation diameter: 07m
	Blade: 12 EA
Generator	Support frame
	AFPM Generator
Load Module	Output : 500W /500RPM
	200V / 50W halogen lamp 5 EA
DC/AC Converter	LCD (RPM Display)
	Input : 80V~150V
	Output voltage: 230VAC
AC load	LCD panel
	AC lamp
Battery	Fan 220VAC/12W
	Rated output voltage : 12V / 12AH
Quick charger	Input : AC220V / 60Hz / 43VA
Wind speed meter	Range: 0~45m/s

Contents of YWEGT-1000 (Blade Type) Textbook

1. Introduction to wind power generation
2. Configuration and structure of wind power generation
3. Understanding wind power generator
4. Measuring power generation vs. wind speed
5. Measuring power generation vs. number of blades
6. Measuring power generation vs. blade angle
7. Measuring RPM vs. load
8. Measuring energy generation and energy conversion
9. Power conversion experiment using DC/AC converter
10. PWM generator manufacturing practice
11. BOOST(Step_Up) type manufacturing practice
12. BUCK(Step_Down) type manufacturing practice
13. BUCK_BOOST(Step_Up/Down) type manufacturing practice
14. CUK(Step_Down) type manufacturing practice
15. Trends and forecast of wind power generation

YWEGT-1000 (Blade Type) components

Components	Unit	Qty
Blower	Unit	1
Blade & generator	Set	1
Load Module	Module	2
DC/AC inverter	Module	1
Battery	EA	1
Quick charger	EA	1
Wind speed meter	Set	1
Connection Cable	Set	1
Textbook		
Power conversion training kit [Option]	Module	5

Wind Energy Generation Training System

Model: YWEGT-1000 Hand Type



YWEGT-1000 (Hand Type) functions

1. Measuring generator's 3-phase output energy
2. Measuring generator rotation vs. hand force
3. Power conversion using converter, inverter and load
4. Magnitude of energy generation vs. load
5. Power conversion circuit manufacturing practice

Contents of YWEGT-1000 (Hand Type) Textbook

1. Introduction to wind power generation
2. Configuration and structure of wind power generation
3. Understanding wind power generator
4. Measuring energy vs. generation speed
5. Features of generator's 3-phase output
6. Measuring energy generation and energy conversion
7. Power conversion practice using DC/AC converter
8. Power conversion practice using DC/AC inverter
9. Power conversion practice using FlyBack inverter
10. PWM generator manufacturing practice
11. BOOST(Step_Up) type manufacturing practice
12. BUCK(Step_Down) type manufacturing practice
13. BUCK_BOOST(Step_Up/Down) type manufacturing practice
14. CUK(Step_Down) type manufacturing practice
15. Trends and forecast of wind power generation

YWEGT-1000 (Hand Type) components

Component	Unit	Qty
Generator	Set	1
Load Module	Module	3
DC/DC converter	Module	1
FlyBack inverter	Module	1
DC/AC inverter	Module	1
Battery	EA	1
Quick charger	EA	1
Connection Cable	Set	1
Textbook		
Power conversion training kit [Option]	Module	5

YWEGT-1000 (Hand Type) features

1. Designed to allow indoor experiments for the principle of wind power generation
2. The system is composed of generator, load, DC/DC converter, DC/AC inverter, FlyBack inverter, battery and quick charger
3. For the purpose of safety, load and inverter modules are contained in a steel enclosure.
4. Experiments are conducted under the same environment as wind power generation by applying force to the generator with hand instead of blade in order to exclude noise involved in wind power generation experiments
5. Check real-time power generation vs. hand force
6. Power conversion practice using DC/DC converter and DC/AC inverter
7. Designed to test and check the magnitude of energy generated
8. Each chapter of the training textbook is composed of theory, practice and report.
9. Manufacturing practice for power conversion and measurement of circuit characteristics

YWEGT-1000 (Hand Type) Part Specification

Part	Specification
Generator	AFPM Generator
	Output : 500W /500RPM
	Supporting frame
Load Module	Including 3-phase full rectifier
	Input : 19V-36V
	Rated output: 12VDC
	Output current: 4.2A
DC/DC converter	Input : 12VDC
	Output voltage : 80-150VDC
	LCD panel
DC/AC inverter	Input : 80V-150VDC
	Output voltage : 230VAC
	LCD panel
FlyBack inverter	Input 12VDC
	Output voltage : 230VAC
	LCD panel
DC load	DC lamp
	Fan (DC 12V/1.5W)
AC load	AC lamp
	Fan (220VAC/12W)
Battery	Output voltage : 12V / 12AH
Quick charger	Input : AC220V / 60Hz / 43VA